

Standard Operating Procedure for the  
Analysis of Silicon in Fresh Waters  
CCAL 32C.1

Cooperative Chemical Analytical Laboratory  
College of Forestry  
Oregon State University  
3015 Western Blvd  
Corvallis, Oregon

Prepared by Kathryn Motter  
And Laura Hartley  
Revised June 2019

# Standard Operating Procedure for the Analysis of Silicon In Fresh Waters CCAL 32C.1

## *Table of Contents*

<b>1.0</b>	<b>Scope and Application .....</b>	<b>3</b>
<b>2.0</b>	<b>Summary of Method .....</b>	<b>3</b>
<b>3.0</b>	<b>Definitions .....</b>	<b>3</b>
<b>4.0</b>	<b>Interferences .....</b>	<b>4</b>
<b>5.0</b>	<b>Safety .....</b>	<b>4</b>
<b>6.0</b>	<b>Equipment and Supplies.....</b>	<b>4</b>
<b>7.0</b>	<b>Reagents and Standards .....</b>	<b>5</b>
<b>7.1</b>	<b>Preparation of Reagents .....</b>	<b>5</b>
<b>7.2</b>	<b>Preparation of Standards .....</b>	<b>6</b>
<b>8.0</b>	<b>Sample Handling and Storage.....</b>	<b>6</b>
<b>9.0</b>	<b>Quality Control .....</b>	<b>7</b>
<b>10.0</b>	<b>Calibration and Standardization .....</b>	<b>7</b>
<b>11.0</b>	<b>Procedure .....</b>	<b>7</b>
<b>11.1</b>	<b>Calibration and Analysis Procedure .....</b>	<b>7</b>
<b>11.2</b>	<b>System Notes .....</b>	<b>8</b>
<b>12.0</b>	<b>Data Analysis and Calculations .....</b>	<b>8</b>
<b>13.0</b>	<b>Method Performance .....</b>	<b>9</b>
<b>14.0</b>	<b>Pollution Prevention .....</b>	<b>9</b>
<b>15.0</b>	<b>Waste Management.....</b>	<b>9</b>
<b>16.0</b>	<b>References .....</b>	<b>9</b>
<b>17.0</b>	<b>Tables, Diagrams, Flowcharts, and Validation Data.....</b>	<b>11</b>
<b>17.1</b>	<b>Silicon Reaction Manifold .....</b>	<b>11</b>
<b>17.2</b>	<b>Data System Parameters.....</b>	<b>12</b>
<b>18.0</b>	<b>Document Revision History.....</b>	<b>12</b>

# Standard Operating Procedure for the Analysis of Silicon In Fresh Waters CCAL 32C.1

## 1.0 Scope and Application

- 1.1 This method details the determination of silicon in fresh waters by automated flow injection, colorimetric analysis. The practical range of determination for this method is 0.20 to 10.00 mg Si/L. Method detection limit for this analysis is 0.05 mg/L as silicon.

## 2.0 Summary of Method

- 2.1 An automated analysis method is used for the colorimetric determination of silicon in fresh water. Silica reacts with molybdate in an acidic environment to form yellow beta-molybdosilicic acid. The acid is reduced by aminonaphtholsulfonic acid to form a heteropoly molybdous-blue complex that absorbs at 820 nm. Concentration of silicon is determined by comparison of absorbance signal with calibration results obtained from prepared standards of varying concentrations.

## 3.0 Definitions

- 3.1 DI water: Water that has been through a deionization system to produce water similar to ASTM Type I reagent with 16.7 Mohms resistivity (ASTM) (Reference 16.3).
- 3.2 Method Detection Limit (MDL): The minimum concentration of an analyte that can be measured and reported with 99% confidence, based on a one-sided 99% confidence interval ( $t$ -value at a significance level of 0.01 and  $n-1$  degrees of freedom) from at least seven repeated measurements of a low concentration standard measured within an analysis run.

$$\text{MDL} = ts$$

Where,

$t$  = Student's  $t$  value at a significance level of 0.01 and  $n-1$  degrees of freedom

$s$  = standard deviation of at least seven repeated measurements of a low level standard

## 4.0 Interferences

- 4.1 Oxalic acid is added to the sample stream before addition of reducing agent to minimize interference from phosphates, and reduce tannin interferences.
- 4.2 Large amounts of tannin, iron, color, turbidity and sulfide interfere.
- 4.3 Freezing samples may reduce silicon concentration (Reference 16.1)
- 4.4 Samples, standards and reagents should be stored in polyethylene containers. Avoid using glassware.
- 4.5 Turbidity and color that persists in the sample after filtration may absorb at 820 nm. Reanalyze samples without the color reagent as turbidity/color blanks. Any response from the turbidity/color blanks must then be subtracted from the initial analysis response.

## 5.0 Safety

- 5.1 The toxicity or carcinogenicity of each reagent has not been precisely determined; however, each chemical should be regarded as a potential health hazard. Exposure to these chemicals should be reduced to the lowest possible level. Cautions are included for known extremely hazardous materials.
- 5.2 The following chemicals have the potential to be highly toxic or hazardous. For detailed explanations, consult the MSDS.
  - 5.2.1 Sulfuric acid
  - 5.2.2 Oxalic acid
  - 5.2.3 Sodium Bisulfite
  - 5.2.4 1-amino-2-naphthanol-4-sulfonic acid

## 6.0 Equipment and Supplies

**Note:** *Brand names, suppliers and part numbers are for illustrative purposes only. No endorsement is implied. Equivalent performance may be achieved using apparatus and*

*materials other than those specified here, but demonstration of equivalent performance that meets the requirements of this method is the responsibility of the laboratory.*

---

- 6.1 Balance measuring to at least 0.1 mg
- 6.2 Polyethylene volumetric flasks and pipettes as required
- 6.3 Lachat QuikChem 8500 Flow Injection Analyzer
  - 6.3.1 Multichannel proportioning pump (peristaltic)
  - 6.3.2 XYZ Autosampler
  - 6.3.3 Reaction Manifold
  - 6.3.4 Colorimetric Detector
  - 6.3.5 Data System
- 6.4 Safety glasses
- 6.5 Nitrile gloves
- 6.6 Lab coat or apron
- 6.7 Laboratory exhaust fume hood
- 6.8 High density polyethylene (HDPE) bottles

## **7.0 Reagents and Standards**

### **7.1 Preparation of Reagents**

---

*Reagents 1 & 2 need to be filtered and degassed with He*

---

#### **7.1.1 Ammonium Molybdate:**

In a 500 mL volumetric flask, dissolve 20.0 g of ammonium molybdate in approximately 400 mL of DI water. Add 8 mL concentrated sulfuric acid. Dilute to the mark. Filter and degas. Store in amber polyethylene container. Solution should be prepared monthly. Discard if precipitation occurs or blue color develops.

#### **7.1.2 Oxalic Acid:**

Dissolve 50 g of oxalic acid in approximately 450 mL of DI water in a 500 mL volumetric flask. When dissolution complete, dilute to the mark. Filter and degas. Store in amber polyethylene container. Reagent is stable.

### 7.1.3 ANSA Reducing Agent:

Dissolve 2.0 g sodium sulfite ( $\text{Na}_2\text{SO}_3$ ) in approximately 80 mL of water in a 100 mL volumetric flask. Add 0.25 g ANSA (1-amino-2-naphthol-4-sulfonic acid). Dilute to the mark. Prepare a second solution by dissolving 15 g sodium bisulfite ( $\text{NaHSO}_3$ ) in 300 mL DI water. Mix the two solutions into an amber plastic container. Add 4 mL glycerol. Store in the refrigerator. Discard when dark in color.

## 7.2 Preparation of Standards

### 7.2.1 Calibration Standards

Standards are prepared by dilution of a single element standard purchased from a vendor that provides traceability to NIST standards. The stock standard is used to prepare working standards in the table below.

	mg SiO <sub>2</sub> -Si/L
1	1.0
2	2.5
3	5.0
4	10.0
5	15.0

### 7.2.2 Second Source Check Standard:

Standards are prepared by dilution of a standard purchased from a vendor that provides traceability to NIST standards; this reagent is from a source other than that of the calibration standards or a different lot number from the same vendor. A mixed stock standard is prepared by dilution of the purchased reagent to an intermediate concentration. Check standard concentrations are the same as calibration standard 3.

## 8.0 Sample Handling and Storage

- 8.1 Unfiltered samples are filtered upon receipt through glass fiber filters into clean HDPE bottles and stored at 4°C in the dark. Samples are analyzed within 28 days to ensure sample integrity, although Si has been found to be stable for much longer. If samples must be held prior to analysis, they are stored refrigerated at 4°C.

## 9.0 Quality Control

- 9.1 Preparation of standards is recorded on worksheets and documented by weight of standard added to a given flask before dilution to volume with DI water. All records of certification are kept on file at CCAL Laboratory.
- 9.2 Blank: DI water run after the calibration and before and after each check standard.
- 9.3 Quality Control Check Standard: Calibration standards run in rotation every ten samples to monitor stability and validate the calibration.
- 9.4 Method Detection Limit (MDL): Established for each analyte. Based on a one-sided 99% confidence interval (t-value) from at least seven repeated measurements of a low concentration standard. The t-distribution value is multiplied by the standard deviation of the population (n-1) to obtain the MDL.
- 9.5 Analytical Duplicate: Separate analysis from the same sample aliquot. Run a minimum of once every ten samples.

## 10.0 Calibration and Standardization

- 10.1 Balances: calibrated yearly by external vendor.
- 10.2 Pipette delivery checked by weight to within 1% of theoretical weight of aliquot volume.
- 10.3 Calibration curve with  $r^2 \geq 0.995$ . (See 17.3 for calibration data set-up.)
- 10.4 Calibration verification with check standards, monitored throughout the run. If measurement exceeds +/- 10% of the theoretical value, the analysis should be terminated and the instrument recalibrated. The calibration must be verified before continuing analysis.

## 11.0 Procedure

- 11.1 Calibration and Analysis Procedure
  - 11.1.1 Prepare reagents and standards as outlined in Section 7.
  - 11.1.2 Set up manifolds as shown in Section 17.1.

- 11.1.3 Samples are injected into the reaction path at a fixed time interval. Setup or confirm data system parameters as detailed in Section 17.2.
- 11.1.4 Pump DI water through all reagent lines until stable flow. Check for leaks, even flow, and monitor baseline. Pump reagents through all lines until the system equilibrates. Monitor baseline until stable.
- 11.1.5 Record sample ids in the data template.
- 11.1.6 Calibrate the instrument with standards. Calibration regression equations must have  $r^2 \geq 0.995$ .
- 11.2 System Notes
- 11.2.1 If the baseline is excessively noisy, clean the manifold using the following procedure:
- Place all reagent and carrier lines in DI water and pump to clear reagents.
  - Place all lines in 20% Contrad NF solution for 20 minutes.
  - Place lines in DI water and pump until thoroughly rinsed.
  - Pump startup solution through reagent lines until stable baseline is achieved.
- 11.2.2 If baseline has a large number of air spikes, check pump tubes for excessive wear and replace as necessary.
- 11.2.3 Use plastic autosampler vials for samples; not glass.
- 11.2.4 Turbidity and color that persists in the sample after filtration may absorb at the 820 nm. Reanalyze samples without the color reagent as turbidity/color blanks. Any response from the turbidity/color blanks must then be subtracted from the initial analysis response.

## 12.0 Data Analysis and Calculations

- 12.1 The data system prepares a calibration curve by plotting response of injected standards versus known standard concentration. The resulting regression equation is used to calculate the sample concentration.
- 12.2 All results and sample information are filed in the analysis data system by analysis run. Details specific to the instrumental analysis are noted in the Instrument Run Log created and maintained for the Lachat Quikchem. Analytical results are entered into electronic format and entries are verified by a second person.
- 12.3 Historically, CCAL has reported results as mg Si/L. To convert from Si to SiO<sub>2</sub>, multiply by 2.137.



## 13.0 Method Performance

- 13.1 This method was validated through inter-laboratory studies. The CCAL Water Analysis Laboratory participates in the USGS Standard Reference Water QA program and the National Water Research Institute's (NWRI) Environment Canada Proficiency Testing (PT) Program.

## 14.0 Pollution Prevention

- 14.1 The chemicals used in this method pose little threat to the environment when properly managed.
- 14.2 All standards and reagents should be prepared in volumes consistent with laboratory use to minimize the volume of disposable waste.
- 14.3 For further information on pollution prevention, consult *Less is Better: Guide to Minimizing Waste in Laboratories*, available from the American Chemical Society at [www.acs.org](http://www.acs.org).

## 15.0 Waste Management

- 15.1 It is the laboratory's responsibility to comply with all federal, state and local regulations governing waste management, and to protect the environment by minimizing and controlling all releases from fume hoods and bench operations. Compliance with all sewage discharge permits and regulations is required.
- 15.2 For further information on waste management, consult *Less is Better: Guide to Minimizing Waste in Laboratories*, available from the American Chemical Society at [www.acs.org](http://www.acs.org), and *Environmental Management Guide For Small Laboratories* (233B00001) from the US Environmental Protection Agency at <https://nepis.epa.gov>.

## 16.0 References

- 16.1 Standard Methods For The Examination of Water and Wastewater, Method 4500-SiO<sub>2</sub>, Automated Method for Molybdate-Reactive Silica. American Public Health Association. 22<sup>nd</sup> Edition, 2012.

- 16.2 Code of Federal Regulations. Protection of Environment. Section 40, Appendix B to Part 136. Definition and procedure for the determination of the method detection limit. Revision 1.11. Revised July 1, 1990. Office of the Federal Register, National Archives and Records.
- 16.3 ASTM. American Society for Testing and Materials. Standard Specifications for Reagent Water. D1193-77 (Reapproved 1983). Annual Book of ASTM Standards, Vol. 11.01. ASTM: Philadelphia, PA, 1991.
- 16.4 Lachat Instruments Methods Manual. Determination of Silica in Waters by Flow Injection Analysis 10-114-27-1-A. Lachat Instruments, 5600 Lindburgh Drive, Loveland CO 80539.
- 16.5 U.S. Environmental Protection Agency, Methods for Chemical Analysis of Water and Wastes, EPA-600/4-79-020, Revised March 1983, Method 370.1.

## 17.0 Tables, Diagrams, Flowcharts, and Validation Data

### 17.1 Silicon Reaction Manifold

#### 17.3. SILICA MANIFOLD DIAGRAM

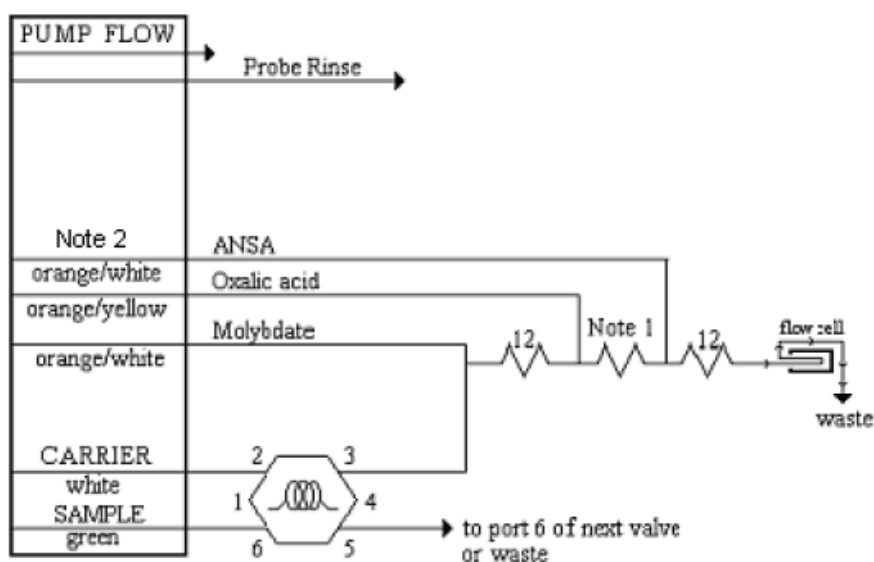

**Carrier:** DI water

**Manifold Tubing:** 0.5 mm (0.022 in) i.d. This is 2.5 µL/cm.

**AE Sample Loop:** 7 cm

**QC8000 Sample Loop:** 13 cm

**Interference Filter:** 820 nm

**Apparatus:** An injection valve, a 10 mm path length flow cell, and a colorimetric detector module is required.

**12:** 255 cm of tubing on a 12 cm coil support

**22:** 550 cm of tubing on a 22 cm coil support

**Note 1:** The manifold will come with a 12 cm coil here. This can be replaced with a 22 cm coil, which is included with a new manifold. See Interferences.

**Note 2:** Use 90 cm of 0.8 mm tubing with a Teflon PTA as line weight for all reagents in place of PVC and glass line weight transmission lines. Each pump tube will require 2 PTA's and two collars for connections. (Glass can cause contamination by leaching silicate).

## 17.2 Data System Parameters

Cycle throughput: 60 samples/hr

Cycle Period: 60 s

### Analyte Data:

Concentration Units: mg Si/L

### Calibration Data:

Calibration Fit Type: 1<sup>st</sup> Order

### Sampler Timing:

Minimum Probe in Wash Period: 5 s

Probe in Sample Period: 20 s

## 18.0 Document Revision History

Original Document: March 2006

Version: 32A.0

Title: Standard Operating Procedure for the Analysis of Silica in Fresh Waters

Edit Date: February 2010

New Version: 32A.1

Section 7.2: change preparation of standards from raw materials, to serial dilution of purchased standards. Change standard concentrations. Add Second Source Check Standard.

Section 13.1: add Environment Canada Proficiency Testing Program participation

Section 17.2: change standard concentrations and order of standards.

Edit Date: April 2014

New Version: 32A.2

Section 1: change working range of method for appropriate significant figures.

Section 7.1: change preparation frequency for ammonium molybdate. Change surfactant addition for preparation of ascorbic acid.

Section 7.2: Add table for standards.

Section 8.0: change holding time for analysis.

Section 17: clarify section headings.

General editing.

Edit Date: April 2018

New Version: 32B.1

Change in instrumentation from Technicon AAI to Astoria Analyzer, 4/19/2017

Change in chemistry from Technicon 105-71W/B to 4500-SiO<sub>2</sub> E, 4/19/2017

Change to FASpac software, 8/10/2015

Changes throughout document to reflect instrument/chemistry changes

Title change from Silica to Silicon; changed throughout document

Title Page: new author, address change

Section 1: change in calibration range

Edit Date: June 2019

New Version: 32C.1

Change in instrumentation from Astoria Analyzer to Lachat Quikchem 8500 Flow Injection Analyzer, effective 2/7/2019.

Updates throughout to reflect changes in chemistry and instrumentation.

Update APHA reference and add EPA reference

General editing.