

Standard Operating Procedure for the
Analysis of Fresh Water Samples for
Orthophosphorus
CCAL 34D.2

Cooperative Chemical Analytical Laboratory
College of Forestry
Oregon State University
3015 Western Blvd
Corvallis, Oregon

Prepared by Kathryn Motter
And Laura Schmittner
Revised May 2026

**Standard Operating Procedure for the
Analysis of Fresh Water Samples for Orthophosphorus
CCAL 34D.2**

Table of Contents

1.0	Scope and Application	3
2.0	Summary of Method	3
3.0	Definitions	3
4.0	Interferences	4
5.0	Safety	4
6.0	Equipment and Supplies.....	5
7.0	Reagents and Standards	5
7.1	Preparation of Reagents	5
7.2	Preparation of Standards	6
8.0	Sample Handling and Storage.....	6
9.0	Quality Control	7
10.0	Calibration and Standardization	7
11.0	Procedure	7
11.1	Calibration and Analysis Procedure	7
11.2	System Notes	8
12.0	Data Analysis and Calculations	8
13.0	Method Performance	9
14.0	Pollution Prevention	9
15.0	Waste Management.....	9
16.0	References	9
17.0	Tables, Diagrams, Flowcharts, and Validation Data.....	10
17.1	Orthophosphorus Reaction Manifold	10
17.2	Orthophosphorus Manifold Specifications	11
18.0	Document Revision History.....	12

Standard Operating Procedure for the Analysis of Fresh Water Samples for Orthophosphorus CCAL 34D.2

1.0 Scope and Application

- 1.1 This method covers the determination of orthophosphorus in fresh waters in the range of 0.001 - 0.200 mg P/L. Sample concentrations greater than 0.200 mg P/L may be analyzed by dilution of the sample prior to analysis, or by calibration to a higher range.

2.0 Summary of Method

- 2.1 Phosphorus occurs in fresh waters almost solely in the form of various phosphates. Phosphates that can be analyzed colorimetrically without preliminary acid hydrolysis or oxidative digestion are defined as “reactive phosphorus”. Soluble reactive phosphorus (SRP) exists in both dissolved and suspended forms. It is predominately composed of orthophosphorus, but may include a small fraction of condensed phosphate inevitably hydrolyzed during the procedure. Because of this predominance of orthophosphorus, reactive phosphorus is commonly called orthophosphorus, as it is within this method. Orthophosphorus is determined colorimetrically by reaction of ammonium molybdate and antimony potassium tartrate to form phosphomolybdic acid, which is then reduced to intensely colored molybdenum blue by ascorbic acid.

3.0 Definitions

- 3.1 DI water: Water that has been through a deionization system to produce water similar to ASTM Type I reagent with 16.7 Mohms resistivity (ASTM) (Reference 16.3).
- 3.2 Method Detection Limit (MDL): The minimum concentration of an analyte that can be measured and reported with 99% confidence, based on a one-sided 99% confidence interval (t -value at a significance level of 0.01 and $n-1$ degrees of freedom) from at least seven repeated measurements of a low concentration standard measured within an analysis run.

$$\text{MDL} = ts$$

Where,

t = Student's t value at a significance level of 0.01 and $n-1$ degrees of freedom

s = standard deviation of at least seven repeated measurements of a low level standard

4.0 Interferences

- 4.1 Arsenates at concentrations as low as 0.1 mg/l, react with molybdate reagent to produce a blue color resulting in positive interference in colorimetric analysis at 880 nm.
- 4.2 Nitrite and hexavalent chromium interfere to give low analytical results at concentrations as low as 1.0 mg/l.
- 4.3 Silica also complexes with molybdate, and high silica concentrations may result in a positive interference. Approximately 30 mg SiO₃/L produces a 0.005 mg P/L positive interference.
- 4.4 Iron concentrations greater than 50 mg/L cause precipitation and loss of orthophosphate. This interference may be overcome by sample pretreatment with sodium bisulfite.

5.0 Safety

- 5.1 The toxicity or carcinogenicity of each reagent has not been precisely determined; however, each chemical should be regarded as a potential health hazard. Exposure to these chemicals should be reduced to the lowest possible level. Cautions are included for known extremely hazardous materials.
- 5.2 The following chemicals have the potential to be highly toxic or hazardous. For detailed explanations, consult the MSDS.
 - 5.2.1 Sulfuric acid
 - 5.2.2 Antimony potassium tartrate
 - 5.2.3 Dodecyl sulfate

6.0 Equipment and Supplies

Note: Brand names, suppliers and part numbers are for illustrative purposes only. No endorsement is implied. Equivalent performance may be achieved using apparatus and materials other than those specified here, but demonstration of equivalent performance that meets the requirements of this method is the responsibility of the laboratory.

- 6.1 Balance measuring to at least 0.1 mg
- 6.2 Volumetric flasks and pipettes as required
- 6.3 Lachat QuikChem 8500 Flow Injection Analyzer
 - 6.3.1 Multichannel proportioning pump (peristaltic)
 - 6.3.2 XYZ Autosampler
 - 6.3.3 Reaction Manifold
 - 6.3.4 Colorimetric Detector
 - 6.3.5 Data System
 - 6.3.6 Heating Unit
- 6.4 Safety glasses
- 6.5 Nitrile gloves
- 6.6 Lab coat or apron
- 6.7 Laboratory Exhaust Fume Hood
- 6.8 High density polyethylene (HDPE) bottles

7.0 Reagents and Standards

7.1 Preparation of Reagents

All reagents need to be filtered and degassed with He

- 7.1.1 *Stock ammonium molybdate solution*
Add 40 g $(\text{NH}_4)_6\text{Mo}_7\text{O}_{24} \cdot 4\text{H}_2\text{O}$ to approximately 800 mL of DI water in a 1 L volumetric flask. Fill to the mark with DI water. Stir for four hours. Store in plastic and refrigerate at 4C. Stable for up to two months until precipitate forms.
- 7.1.2 *Stock antimony potassium tartrate solution*
Dissolve 1.6 g antimony potassium tartrate ($\text{C}_8\text{H}_4\text{K}_2\text{Sb}_2\text{O}_{12} \cdot 3\text{H}_2\text{O}$) in 400 mL DI water in a 500 ml volumetric flask. Bring to

volume with DI water. Store in a dark bottle and refrigerate at 4C. Stable for up to two months.

7.1.3 *Molybdate color reagent*

To a 500 mL volumetric flask containing approximately 300 mL DI water, slowly add 17.5 mL concentrated sulfuric acid. (*Caution! Solution gets hot!*) Swirl to mix. When cool, add 36.0 mL stock antimony potassium tartrate solution and 107 mL stock ammonium molybdate solution. Prepare fresh weekly. Discard solution if the color deteriorates (i.e., gets darker or precipitates). The reagent must be stored in the dark.

7.1.4 *Ascorbic acid, 0.33 M*

Dissolve 30.0 g of ascorbic acid in a 500 mL volumetric flask containing approximately 350 mL DI water. Dilute to the mark with DI water. Add 0.5 g dodecyl sulfate. Stable two days. Discard if solution yellows.

7.2 Preparation of Standards

7.2.1 *Calibration Standards:*

Standards are prepared by dilution of a standard purchased from a vendor that provides traceability to NIST standards. A stock standard is prepared by dilution of the purchased reagent to an intermediate concentration. The stock standard is used to prepare working standards in the table below.

	mg PO ₄ P/L
1	0.010
2	0.050
3	0.100
4	0.200

7.2.2 *Second Source Check Standard:*

Standards are prepared by dilution of a standard purchased from a vendor that provides traceability to NIST standards; this reagent is from a source other than that of the calibration standards. A stock standard is prepared by dilution of the purchased reagent to an intermediate concentration. Check standard concentrations are the same as calibration standard 3.

8.0 Sample Handling and Storage

- 8.1 If required, unfiltered samples are filtered upon receipt through glass fiber filters into clean HDPE bottles and stored at 4°C in the dark. Samples

should be analyzed within 48 hours to ensure sample integrity. If samples must be held prior to analysis, they are stored frozen at -15°C.

9.0 Quality Control

- 9.1 Preparation of stock standards is recorded on worksheets and documented by weight of standard added to a given flask before dilution to volume with DI water. All records of certification are kept on file at CCAL Laboratory.
- 9.2 Blank: DI water run before the calibration and after check standards.
- 9.3 Method Detection Limit (MDL): Established for each analyte. Based on a one-sided 99% confidence interval (t-value) from at least seven repeated measurements of a low concentration standard. The t-distribution value is multiplied by the standard deviation of the population (n-1) to obtain the MDL.
- 9.4 Analytical Duplicate: Separate analysis from the same sample aliquot. Run a minimum of once every analysis set.
- 9.5 Standard recoveries are tracked over time to monitor overall performance.

10.0 Calibration and Standardization

- 10.1 Balances: calibrated yearly by external vendor.
- 10.2 Pipette delivery checked by weight to within 2% of theoretical weight of aliquot volume.
- 10.3 Calibration curve with $r^2 \geq 0.995$. (See 17.3 for calibration data set-up.)
- 10.4 Calibration verification with check standards, monitored throughout the run. If measurement exceeds +/- 10% of the theoretical value, the analysis should be terminated and the instrument recalibrated. The calibration must be verified before continuing analysis.

11.0 Procedure

- 11.1 Calibration and Analysis Procedure

- 11.1.1 Prepare reagents and standards as outlined in Section 7.
- 11.1.2 Set up manifolds as shown in Section 17.1.
- 11.1.3 Samples are injected into the reaction path at a fixed time interval, determined by timing set in the software. Setup or confirm data system parameters as detailed in Section 17.2.
- 11.1.4 Pump DI water through all reagent and sample lines. Check for leaks, even flow and monitor for stable baseline. Pump reagents through until the system equilibrates. Monitor until baseline is stable.
- 11.1.5 Record sample id's in the data template.
- 11.1.6 Calibrate the instrument with standards. Calibration regression equations must have $r^2 \geq 0.995$.

11.2 System Notes

- 11.2.1 If the baseline is excessively noisy, clean the manifold using the following procedure:
 - Place all reagent and carrier lines in rinse water and pump to clear reagents.
 - Place all lines in alkaline Chemwash or 20% Contrad for several minutes.
 - Place lines in DI water and pump until thoroughly rinsed.
- 11.2.2 If baseline has a large number of air spikes, check pump tubes for excessive wear and replace as necessary.
- 11.2.3 Poor sensitivity, insufficient color development or abnormal peak shape may be the result of old ammonium molybdate solution. Prepare fresh and flush system thoroughly.
- 11.2.4 Turbidity and color that persists in the sample after filtration may absorb at the 880 nm. Reanalyze samples with color reagent prepared without ascorbic acid as turbidity/color blanks. Any response from the turbidity/color blanks must then be subtracted from the initial analysis response.
- 11.2.5 Use plastic autosampler vials for samples; not glass.

12.0 Data Analysis and Calculations

- 12.1 The data system prepares a calibration curve by plotting response of injected standards versus known standard concentration. The resulting regression equation is used to calculate the sample concentration.
- 12.2 All results and sample information are filed in the analysis data system by analysis run. Details specific to the instrumental analysis are noted in the Instrument Run Log created and maintained for the AAI. Analytical

results are entered into electronic format and entries are verified by a second person.

13.0 Method Performance

- 13.1 This method was validated through inter-laboratory studies. The CCAL Water Analysis Laboratory participates in the USGS Standard Reference Water QA Proficiency Testing (PT) Program.

14.0 Pollution Prevention

- 14.1 The chemicals used in this method pose little threat to the environment when properly managed.
- 14.2 All standards and reagents should be prepared in volumes consistent with laboratory use to minimize the volume of disposable waste.
- 14.3 For further information on pollution prevention, consult *Less is Better: Guide to Minimizing Waste in Laboratories*, available from the American Chemical Society at www.acs.org.

15.0 Waste Management

- 15.1 It is the laboratory's responsibility to comply with all federal, state and local regulations governing waste management, and to protect the environment by minimizing and controlling all releases from fume hoods and bench operations. Compliance with all sewage discharge permits and regulations is required.
- 15.2 For further information on waste management, consult *Less is Better: Guide to Minimizing Waste in Laboratories*, available from the American Chemical Society at www.acs.org, and *Environmental Management Guide For Small Laboratories* (233B00001) from the US Environmental Protection Agency at <https://nepis.epa.gov>.

16.0 References

- 16.1 Standard Methods For The Examination of Water and Wastewater, Method 4500-P Phosphorus; 4500-P G. Flow Injection Analysis for

- Orthophosphorus. American Public Health Association. 21st Edition, 2005.
- 16.2 Code of Federal Regulations. Protection of Environment. Section 40, Appendix B to Part 136. Definition and procedure for the determination of the method detection limit. Revision 1.11. Revised July 1, 1990. Office of the Federal Register, National Archives and Records.
- 16.3 ASTM. American Society for Testing and Materials. Standard Specifications for Reagent Water. D1193-77 (Reapproved 1983). Annual Book of ASTM Standards, Vol. 11.01. ASTM: Philadelphia, PA, 1991.
- 16.4 FWPCA Methods for Chemical Analysis of Water and Wastes.
- 16.5 Murphy J., and J. Riley. "A Modified Single Solution Method for the Determination of Phosphate in Natural Waters." *Anal. Chem. Acta.* 27, 31. 1962.
- 16.6 Gales, M. E., Jr., E. C. Julian, and R. C. Kroner. "Method for Quantitative Determination of Total Phosphorus in Water." *J. AWWA* 58:1363. 1966.
- 16.7 American Water Works Assoc. 1958. Committee Report. "Determination of Ortho Phosphate, Hydrolyzable Phosphate and Total Phosphate in Surface Waters." *J. Am. Water Works Assoc.* 50:1563.
- 16.8 Strickland, J. D. H. and T. R. Parsons. 1965. *A Manual of Sea Water Analysis*, 2nd Ed. Fish Res. Bd., Ottawa, Canada.
- 16.9 Lachat Instruments Methods Manual. Orthophosphate in Waters 10-115-01-1-A. Lachat Instruments, 5600 Lindburgh Drive, Loveland CO 80539.

17.0 Tables, Diagrams, Flowcharts, and Validation Data

- 17.1 Orthophosphorus Reaction Manifold

17.3. ORTHOPHOSPHATE MANIFOLD DIAGRAM

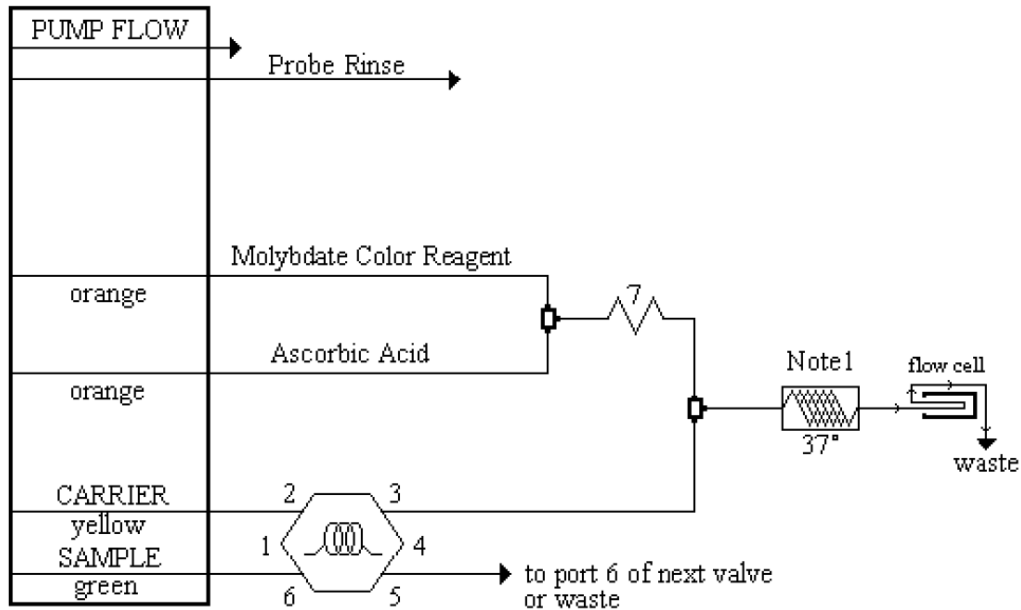

17.2 Orthophosphorus Manifold Specifications

Carrier is DI water

Interference filter is 880 nm

Pump tubing is PVC

Manifold tubing is 0.8 mm i.d.

Sample loop: 75 cm x 0.8 mm i.d.

Mixing coil is 135 cm of tubing on a 7 cm coil support

10 mm path length flow cell

Heater block at 37°C, wrapped with 175 cm of tubing

18.0 Document Revision History

Original Document: April 2006

Version: 40A.0

Title: Standard Operating Procedure for the Analysis of Fresh Water Samples for Orthophosphorus

Edit Date: July 2008

New Version: 34B.0

Document updated to reflect change to automated method of analysis

Edit Date: February 2010

New Version: 34B.1

Address update

Section 7.2: delete silica from mixed standard

Section 13.1: add Environment Canada Proficiency Testing Program participation.

Edit Date: April 2014

New Version: 34B.2

Section 1: change working range of method for appropriate significant figures.

Section 7.1: update reagent preparation of sodium laurel sulfate. Add EDTA cleaning reagent preparation.

Section 8.0: add specific sample hold time.

Section 11.2: change cleaning reagent.

Section 17.2: change carrier.

General editing.

Edit Date: February 2019

New Version: 34C.1

Address update

Update document to Astoria Pacific Analyzer from the Technicon

Changes throughout to reflect new chemistry and instrumentation settings

Changed to single element standards; calibration and second source

Changes effective April 20, 2017

Edit Date: June 2019

New Version: 34D.1

Update to Lachat QuikChem 8500 Flow Injection Analyzer.

Updates throughout to reflect new chemistry and instrumentation.

Change from the Astoria Pacific Analyzer to the Lachat QuikChem 8500 effective March 5, 2019.

Edit Date: May 2026

New Version: 34D.2

Section 9: update frequency of blanks

Section 11: add note regarding use of plastic tubes

Section 13: remove NWRI participation

General editing throughout