

Standard Operating Procedure for the
Analysis of Nitrate/Nitrite and Nitrite
in Fresh Waters
CCAL 31C.1

Cooperative Chemical Analytical Laboratory
College of Forestry
Oregon State University
3015 Western Blvd
Corvallis, Oregon

Prepared by Kathryn Motter
And Laura Hartley
Revised June 2019

Standard Operating Procedure for the Determination of Nitrate/Nitrite and Nitrite in Fresh Waters CCAL 31C.1

Table of Contents

1.0	Scope and Application	3
2.0	Summary of Method	3
3.0	Definitions	3
4.0	Interferences	4
5.0	Safety	4
6.0	Equipment and Supplies	5
7.0	Reagents and Standards	5
7.1	Preparation of Reagents	5
7.2	Preparation of Cadmium Column.....	6
7.3	Preparation of Standards.....	6
8.0	Sample Handling and Storage	7
9.0	Quality Control	7
10.0	Calibration and Standardization.....	8
11.0	Procedures	8
11.1	Calibration and Analysis Procedure	8
11.2	System Notes	8
12.0	Data Analysis and Calculations.....	9
13.0	Method Performance	9
14.0	Pollution Prevention	9
15.0	Waste Management.....	10
16.0	References	10
17.0	Tables, Diagrams, Flowcharts, and Validation Data.....	11
17.1	Nitrate/Nitrite Nitrogen Reaction Manifold	11
17.2	Nitrate-Nitrite Manifold Specifications.....	11
17.3	Data System Parameters	12
18.0	Document Revision History	12

Standard Operating Procedure for the Determination of Nitrate/Nitrite and Nitrite in Fresh Waters CCAL 31C.1

1.0 Scope and Application

- 1.1 This method details the determination of nitrate/nitrite and nitrite in fresh waters by automated colorimetric analysis. The practical range of determination for this method is 0.001 to 0.100 mg/L as N. Method detection limit for this analysis is 0.001 mg/L N.

2.0 Summary of Method

- 2.1 An automated analysis method is used for the colorimetric determination of nitrate/nitrite and nitrite in fresh waters. Nitrate is reduced to nitrite when passed through a copperized cadmium reduction column. For the analysis of nitrite exclusively, the column is taken out of line. The nitrite is diazotized with sulfanilamide and coupled with N-(1-naphthyl)-ethylenediamine dihydrochloride to form a highly magenta colored azo dye, the absorbance of which is measured colorimetrically at 520 nm. Concentration of nitrate/nitrite or nitrite is determined by comparison of absorbance signal with calibration results obtained from prepared standards of varying concentrations.

3.0 Definitions

- 3.1 DI water: Water that has been through a deionization system to produce water similar to ASTM Type I reagent with 16.7 Mohms resistivity (ASTM) (Reference 16.3).
- 3.2 Method Detection Limit (MDL): The minimum concentration of an analyte that can be measured and reported with 99% confidence, based on a one-sided 99% confidence interval (t -value at a significance level of 0.01 and $n-1$ degrees of freedom) from at least seven repeated measurements of a low concentration standard measured within an analysis run.

$$\text{MDL} = ts$$

Where,

t = Student's t value at a significance level of 0.01 and $n-1$ degrees of freedom

s = standard deviation of at least seven repeated measurements of a low level standard

4.0 Interferences

- 4.1 Oxidizing and reducing agents and metal ions that could potentially cause interference are generally found at negligible concentrations in unpolluted surface and groundwaters.
- 4.2 High concentrations of iron, copper or other metals result in negative interference. EDTA is added to the buffer to minimize this effect.
- 4.3 Turbidity and color that persists in the sample after filtration may absorb at the 520 nm. Reanalyze samples without the color reagent as turbidity/color blanks. Any response from the turbidity/color blanks must then be subtracted from the initial analysis response.
- 4.4 Residual chlorine may interfere by oxidation of the cadmium column.

5.0 Safety

- 5.1 The toxicity or carcinogenicity of each reagent has not been precisely determined; however, each chemical should be regarded as a potential health hazard. Exposure to these chemicals should be reduced to the lowest possible level. Cautions are included for known extremely hazardous materials.
- 5.2 The following chemicals have the potential to be highly toxic or hazardous. For detailed explanations, consult the MSDS.
 - 5.2.1 Hydrochloric acid
 - 5.2.2 Phosphoric acid
 - 5.2.3 Sodium hydroxide
 - 5.2.4 Ammonium hydroxide
 - 5.2.5 N-(1-naphthyl)-ethylenediamine dihydrochloride
 - 5.2.6 Cadmium
 - 5.2.7 Sufanilamide

6.0 Equipment and Supplies

Note: *Brand names, suppliers and part numbers are for illustrative purposes only. No endorsement is implied. Equivalent performance may be achieved using apparatus and materials other than those specified here, but demonstration of equivalent performance that meets the requirements of this method is the responsibility of the laboratory.*

- 6.1 Analytical balance with resolution to 0.1 mg
- 6.2 Glassware: including volumetric flasks and pipettes as required
- 6.3 Lachat QuikChem 8500 Flow Injection Analyzer
 - 6.3.1 Multichannel proportioning pump (peristaltic)
 - 6.3.2 XYZ Autosampler
 - 6.3.3 Reaction Manifold
 - 6.3.4 Colorimetric Detector
 - 6.3.5 Data System
- 6.4 Safety glasses
- 6.5 Nitrile gloves
- 6.6 Lab coat or apron
- 6.7 Laboratory exhaust fume hood
- 6.8 High density polyethylene (HDPE) bottles

7.0 Reagents and Standards

7.1 Preparation of Reagents

All reagents need to be filtered and degassed with He

- 7.1.1 *15 N Sodium Hydroxide:*
Slowly add 150 g sodium hydroxide to 250 mL DI water. Swirl until dissolved. Cool and store in plastic bottle.
- 7.1.2 *Sulfanilamide Color Reagent:*
Slowly add 100 mL conc phosphoric acid (H₃PO₄) to approximately 800 mL DI water in a 1 L volumetric flask. Add 40.0 g sulfanilamide, and 1.0 g N-(1-naphthyl)-ethylenediamine dihydrochloride. Stir for 30 minutes or until complete dissolution. Dilute to the mark and invert to mix. Store in a brown bottle and

keep in the dark when not in use. This solution is stable for one month.

7.1.3 *Ammonium Chloride Buffer:*

To 500 mL of DI water in a 1 L volumetric flask, add 105 mL concentrated hydrochloric acid. Swirl to mix. Add 95 mL ammonium hydroxide and 1.0 g disodium EDTA. Stir until dissolution complete. Dilute to the mark. Adjust pH to 8.5 with 15 N NaOH.

7.2 Preparation of Cadmium Column

7.2.1 Check the size of the coarse cadmium granules before washing and discard exceptionally large granules.

7.2.2 Wash granules first with acetone; then with 1N HCl (color should be silvery). At this point the cadmium may be dried and stored in an air-tight container.

7.2.3 Wash the clean cadmium with 50 to 100 mL of 2% CuSO₄ • 5H₂O, until no blue color remains in the solution and the semi-colloidal copper particles begin to enter the supernatant liquid. Rinse with DI water.

7.2.4 Continue to wash with water until cadmium appears black; the number of water rinses is not critical.

7.2.5 Fill the column with ammonium chloride buffer (7.1.3) and transfer the granules to the column.

7.2.6 Condition the column in-line by running Ammonium Chloride Buffer through for 1 hour. Check the column conditioning by analyzing a minimum of six 0.100 mg N/L standards. Results should agree to within 1 %.

7.3 Preparation of Standards

7.3.1 *Calibration Standard:*

Standards are prepared by dilution of a standard purchased from a vendor that provides traceability to NIST standards. A stock standard is prepared by dilution of the purchased reagent to an intermediate concentration. The stock standard is used to prepare working standards in the table below.

	mg NO ₃ -N/L
1	0.005
2	0.025
3	0.050
4	0.100

For preparation of nitrite standards use the concentrations in the table below.

	mg NO ₂ -N/L
1	0.003
2	0.015
3	0.030
4	0.061

7.3.2 *Second Source Check Standard:*

Standards are prepared by dilution of a standard purchased from a vendor that provides traceability to NIST standards; this standard is from a source other than that of the calibration standards. A stock standard is prepared by dilution of the purchased standard to an intermediate concentration. Check standard concentration is the same as calibration standard 3.

8.0 Sample Handling and Storage

- 8.1 Unfiltered samples are filtered upon receipt through glass fiber filters into clean HDPE bottles and stored at 4°C in the dark. Samples are analyzed within 48 hours to ensure sample integrity. If samples must be held prior to analysis, they are stored frozen at -15°C.

9.0 Quality Control

- 9.1 Preparation of stock standards is recorded on worksheets and documented by weight of standard added to a given flask before dilution to volume with DI water. All records of certification are kept on file at CCAL Laboratory.
- 9.2 Blank: DI water run after the calibration and before and after each check standard.
- 9.3 Quality Control Check Standard: Calibration standards run in rotation every ten samples to monitor stability and validate the calibration.
- 9.4 Method Detection Limit (MDL): Established for each analyte. Based on a one-sided 99% confidence interval (t-value) from at least seven repeated measurements of a low concentration standard. The t-distribution value is multiplied by the standard deviation of the population (n-1) to obtain the MDL.

- 9.5 Analytical Duplicate: Separate analysis from the same sample aliquot. Run a minimum of once every ten samples.

10.0 Calibration and Standardization

- 10.1 Balances: calibrated yearly by external vendor.
- 10.2 Pipette delivery checked by weight to within 2% of theoretical weight of aliquot volume.
- 10.3 Calibration curve with $r^2 \geq 0.995$. (See 17.3 for calibration data set-up.)
- 10.4 Calibration verification with check standards, monitored throughout the run. If measurement exceeds +/- 10% of the theoretical value, the analysis should be terminated and the instrument recalibrated. The calibration must be verified before continuing analysis.

11.0 Procedures

- 11.1 Calibration and Analysis Procedure
- 11.1.1 Prepare reagents and standards as outlined in Section 7.
- 11.1.2 Set up manifolds as shown in Section 17.1.
- 11.1.3 Samples are injected into the reaction path at a fixed time interval. Setup or confirm data system parameters as detailed in Section 17.2.
- 11.1.4 Pump DI water through all reagent until stable flow. Check for leaks, even flow, and monitor baseline. Pump reagents through all lines until the system equilibrates. Monitor baseline until stable.
- 11.1.5 Record sample ids in the data template.
- 11.1.6 Calibrate the instrument with standards. Calibration regression equations must have $r^2 \geq 0.995$, or calibration is discarded and repeated.
- 11.2 System Notes
- 11.2.1 If the baseline is excessively noisy, clean the manifold using the following procedure:
- Place all reagent and carrier lines in rinse water and pump to clear reagents.
 - Place all lines in 1.2N HCl solution for several minutes.

- Place lines in DI water and pump until thoroughly rinsed.
 - Be certain that no acid passes through the cadmium column.
- 11.2.2 If the baseline has a large number of air spikes, check pump tubes for excessive wear and replace as necessary.
- 11.2.3 To minimize the potential for microbial growth in the ammonium chloride reagent, rinse the reagent bottle thoroughly with DI water between mixes.
- 11.2.4 Turbidity and color that persists in the sample after filtration may absorb at the 520 nm. Reanalyze samples without the color reagent as turbidity/color blanks. Any response from the turbidity/color blanks must then be subtracted from the initial analysis response.
- 11.2.5 Nitrite standards are unstable at low concentrations. Standards older than seven days should be prepared fresh prior to analysis.

12.0 Data Analysis and Calculations

- 12.1 The data system prepares a calibration curve by plotting response of injected standards versus known standard concentration. The resulting regression equation is used to calculate the sample concentration.
- 12.2 All results and sample information are filed in the analysis data system by analysis run. Details specific to the instrumental analysis are noted in the Instrument Run Log created and maintained for the AAI. Analytical results are entered into electronic format and entries are verified by a second person.

13.0 Method Performance

- 13.1 This method was validated through inter-laboratory studies. The CCAL Water Analysis Laboratory participates in the USGS Standard Reference Water QA program and the National Water Research Institute's (NWRI) Environment Canada Proficiency Testing (PT) Program.

14.0 Pollution Prevention

- 14.1 The chemicals used in this method pose little threat to the environment when properly managed.
- 14.2 All standards and reagents should be prepared in volumes consistent with laboratory use to minimize the volume of disposable waste.

- 14.3 For further information on pollution prevention, consult *Less is Better: Guide to Minimizing Waste in Laboratories*, available from the American Chemical Society at www.acs.org.

15.0 Waste Management

- 15.1 It is the laboratory's responsibility to comply with all federal, state and local regulations governing waste management, and to protect the environment by minimizing and controlling all releases from fume hoods and bench operations. Compliance with all sewage discharge permits and regulations is required.
- 15.2 For further information on waste management, consult *Less is Better: Guide to Minimizing Waste in Laboratories*, available from the American Chemical Society at www.acs.org, and *Environmental Management Guide For Small Laboratories* (233B00001) from the US Environmental Protection Agency at <https://nepis.epa.gov>.

16.0 References

- 16.1 Standard Methods For The Examination of Water and Wastewater, Method 4500-NO₃, Nitrate Nitrogen Automated Cadmium Reduction Method. American Public Health Association. 21st Edition, 2005.
- 16.2 Code of Federal Regulations. Protection of Environment. Section 40, Appendix B to Part 136. Definition and procedure for the determination of the method detection limit. Revision 1.11. Revised July 1, 1990. Office of the Federal Register, National Archives and Records.
- 16.3 ASTM. American Society for Testing and Materials. Standard Specifications for Reagent Water. D1193-77 (Reapproved 1983). Annual Book of ASTM Standards, Vol. 11.01. ASTM: Philadelphia, PA, 1991.
- 16.4 Lachat Instruments Methods Manual. Determination of Nitrate/Nitrite in Surface and Wastewaters by Flow Injection Analysis 10-107-04-1-B. Lachat Instruments, 5600 Lindburgh Drive, Loveland CO 80539.

17.0 Tables, Diagrams, Flowcharts, and Validation Data

17.1 Nitrate/Nitrite Nitrogen Reaction Manifold

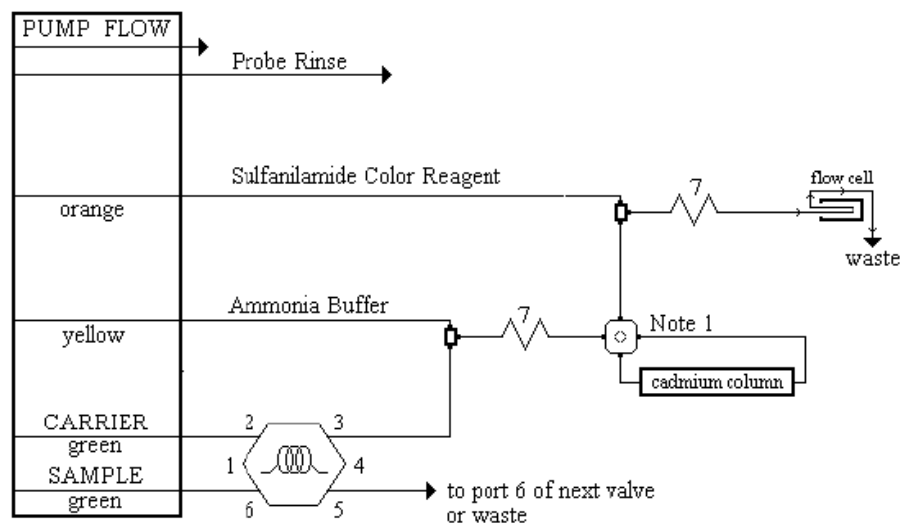

17.2 Nitrate-Nitrite Manifold Specifications

Carrier: DI water

Interference Filter: 520 nm

Pump tubing: PVC

Manifold tubing: 0.8 mm i.d.

Mixing coils: 135 cm tubing on a 7 cm coil support

10 mm flow cell

Backpressure coil, 200 cm x 0.5 mm id tubing

Note: Cadmium Column Switching Valve used to place the column in-line.

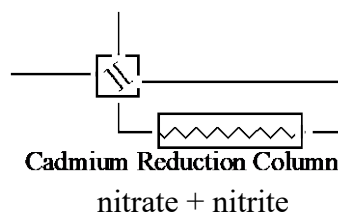
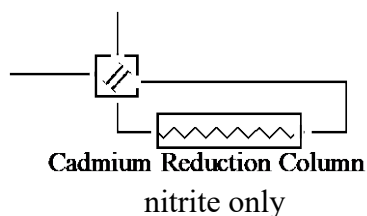

17.3 Data System Parameters

Cycle throughput: 80 samples/hr
 Cycle Period: 45 s

Analyte Data:
 Concentration Units mg N/L

Calibration Data:

Level Nitrate Nitrogen	1	2	3	4
Concentration mg/L	0.005	0.025	0.050	0.100

Level Nitrite Nitrogen	1	2	3	4
Concentration mg/L	0.003	0.015	0.030	0.061

Calibration Fit Type: 1st Order polynomial

Sampler Timing:
 Minimum Probe in Wash Period: 9 s
 Probe in Sample Period: 20 s

18.0 Document Revision History

Original Document: March 2006

Version: 31A.0

Title: Standard Operating Procedure for the Analysis of Nitrate/Nitrite in Fresh Waters

Edit Date: February 2010

New Version: 31B.0

Address update

Add Nitrite procedure and change document title to reflect the addition

Section 7.3: change preparation of standards from raw materials, to serial dilution of purchased standards. Change standard concentrations. Add Second Source Check Standard.

Section 13.1: add Environment Canada Proficiency Testing Program participation.

Section 17.2: change standard concentrations and order of standards.

Edit Date: April 2014

New Version: 31B.1

Section 1: change working range of method with appropriate significant figures.

Section 7.1: update reagent preparation storage for alkaline water.

Section 7.3: add mixed intermediary standard solution and provide a table of final standard concentrations. Add table for nitrite standards.

Section 11.2: add system notes for nitrite standards.

General editing.

Edit Date: June 2019

New Version: 31C.1

Change in instrumentation from Technicon AutoAnalyzer II to Lachat Quikchem 8500 Flow Injection Analyzer, effective 5/1/2019.

Updates throughout to reflect changes in chemistry and instrumentation.

Title Page: new author, address change

General editing throughout